

THIS DRAWING IS UNPUBLISHED. RELEASED FOR PUBLICATION
 © COPYRIGHT BY TYCO ELECTRONICS CORPORATION. ALL RIGHTS RESERVED.

LOC	DIST	REVISIONS					
		P	LTR	DESCRIPTION	DATE	DWN	APVD
G	14		N1	REV PER ECR 08-001337	16JAN07	JR	TM

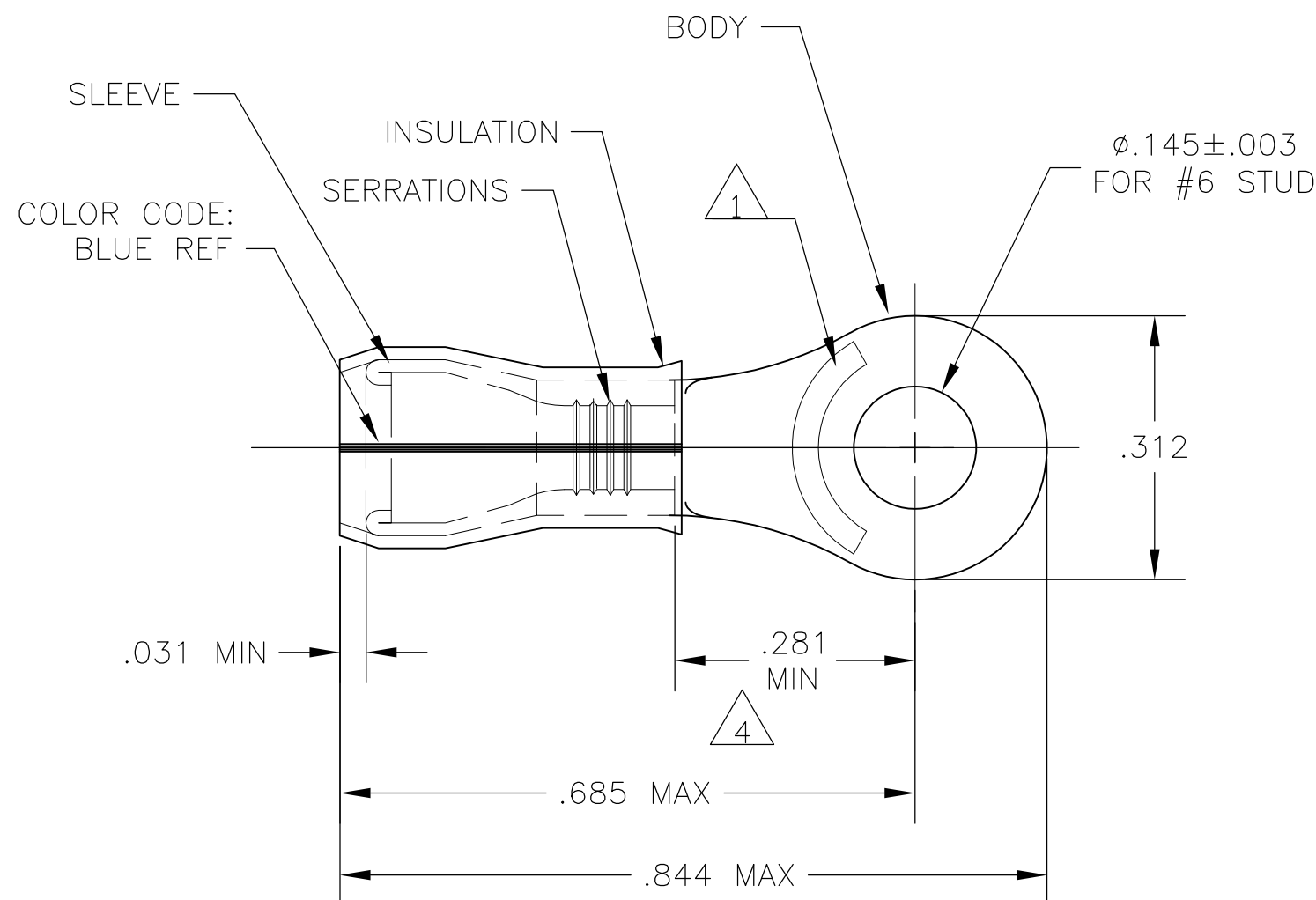

- 1 STAMP AMP 16-14* APPROX AS SHOWN
- 2 WIRE INSULATION DIA: .105-.150
- 3 TONGUE MATERIAL THK: .031±.002
- 4 APPLIES FROM EDGE OF METAL WIRE BARREL TO CENTER OF STUD HOLE.

QTY	PACKAGE TYPE	MATERIAL & FINISH	PART NO
100	LOOSE PIECE, BOX	SAME AS 53416-1	8-53416-1
BULK	LOOSE PIECE	SAME AS 53416-1	8-53416-0
5000	ON TAPE, REEL	SAME AS 53416-1	53416-2
1000	LOOSE PIECE	BODY: COPPER PER ASTM B152 TIN/LEAD (93-7) PLATE PER ASTM B545 (3% MIN LEAD CONTENT) SLEEVE: COPPER PER ASTM B152 TIN/LEAD (93-7) PLATE PER ASTM B545 (3% MIN LEAD CONTENT) INSULATION: PVF2, COLOR-NATURAL	53416-1

THIS DRAWING IS A CONTROLLED DOCUMENT.		DWN JR RUTH 25OCT07	Tyco Electronics Corporation Harrisburg, Pa 17105-3608	
DIMENSIONS: INCHES	TOLERANCES UNLESS OTHERWISE SPECIFIED:	CHK T MICHIELUTTI 25OCT07	NAME TERMINAL, RING TONGUE, PVF2 , P.I.D.G. WIRE SIZE: 16-14 AWG	
	0 PLC ± - 1 PLC ± - 2 PLC ± - 3 PLC ± .008 4 PLC ± - ANGLES ± -	APVD T MICHIELUTTI 25OCT07	PRODUCT SPEC -	RESTRICTED TO -
MATERIAL SEE TABLE	FINISH SEE TABLE	APPLICATION SPEC -	WEIGHT -	SIZE A3
		CAGE CODE 00779		DRAWING NO G-53416
		CUSTOMER DRAWING		SCALE 4:1
		SHEET 1 OF 1		REV N1